

# *Nichipet F II & V II*

Micro pipette for liquid handling

## User's Manual

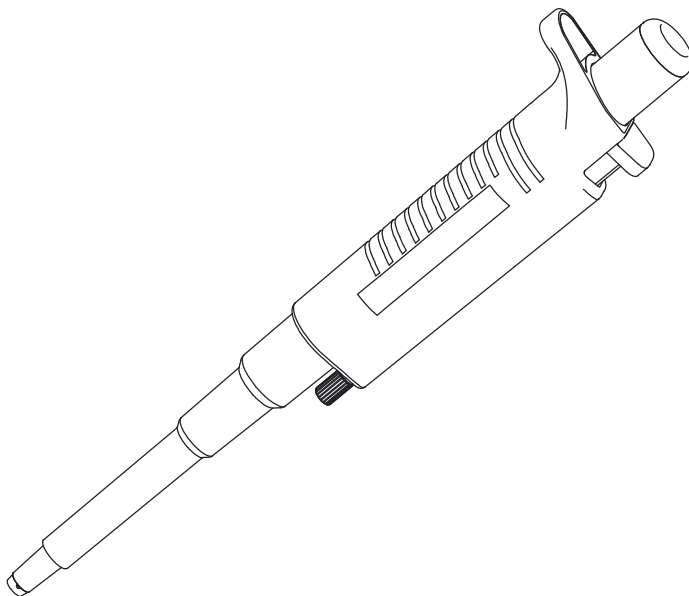

CERTIFIED ISO9001

- Thank you very much for purchasing Nichipet F II & V II.
- Please read this manual carefully before using.



# ***Nichipet F II & V II***

## **Micro pipette for liquid handling**

### **Features**

- New round shape improves friendly handling capability, and mitigates operator's fatigue from long time use.
- Patented body construction avoids permeating hand temperature through the body that prevents inaccuracy of volume measurement.
- Since PTFE (Fluoroplastic) in sealing compound is used in an airtight chamber, this combination keeps airtight and precise reproducibility for long hours.
- Tip can be removed without touching by using the tip ejector.

### **Standard accessories**

- Three tips
- Three filters (NPF2-500, 1000, NPV2-L)
- An adjustment tool (NPF2-500, 1000, NPV2-L)
- User's Manual
- Warranty card

When unpacking package, check to make sure that the above-mentioned items are included.

### **Precautions on safety**

- For using your Nichipet Premium LT properly and safely, carefully read "Precautions on safety" in this paragraph and "CAUTION" on the next page before starting work with it.
- Contents of "CAUTION" are matters that require user's attention, not only for using Nichipet Premium LT properly but for preventing user from accidents and physical damage.
- After reading this manual, please keep it in a convenient place for referring to at any time.

Please read following prior to use for your safety and correct usage.



## CAUTION

Be sure to observe the following instructions for using  
Nichipet FII&VII properly and safely.

If user misuses "Nichipet FII & VII", or disregards the following instructions, it may result in injury to the user or/and other persons or physical damage to pipette or/and other equipment.

1. Do not use pipette for any purpose except pipetting/dispensing liquid.
2. Do not modify pipette, because modification may cause an accident.
3. Do not use pipette for pipetting any liquid to be injected into human body.
4. Do not expel dispensed liquid towards anybody.
5. Do not eject tip towards anybody.
6. Do not eject tip with liquid inside.
7. Carefully handle pipette and tip because tip is sharply pointed.
8. Please make sure that the tips are securely attached to the nozzle. Scattering of liquid will occur if tips fall off the nozzle.
9. If pipette is contaminated with liquid harmful to human, immediately take appropriate disposal to clean it safely before continuing to work.
10. Do not use pipette for stirring liquid and so on, otherwise not only tip may be loose and fall off but the pipette may be soiled with scattered liquid.
11. Do not touch filters which may be contaminated by harmful substances.
12. It may be damaged by chemicals. Please contact to our company when using strong chemicals.
13. Since this pipette is not autoclavable, this pipette never can be autoclaved. It may be deformed or damaged by the heat.
14. Since this pipette is not compatible with UV sterilization, it may be deteriorated or damaged.
15. For organic solvents, Nichipet EX II Plus (NPLO II) will be recommended to use.
16. Pipette can be used between +4°C and +40°C, but the specifications may vary.
17. Depending on frequency of use, pipette should be cleaned in a soap solution and airtight chamber should be maintained according to this manual.

## Note

**Users are required to strictly observe the followings in order for the pipette to keep its excellent precision, reproducibility and original performance for a long time.**

1. Do not expose pipette directly to the sun when working with it or for 2 hours before starting work, otherwise the pipette may lose accuracy. Avoid working with pipettes in a humid and hot place.
2. Just before starting work with pipette, avoid touching tip and nozzle cylinder as far as conditions are allowed. If nozzle cylinder is warmed by your hand, accuracy may vary.
3. For pipetting, follow the forward method (the way explained in this manual). If it is performed in a different way, it may result in inaccurate pipetting.
4. Operate push button very gently. If it is quickly released, it may result not only inaccurate pipetting but also deteriorated the pipette because sample liquid may be permeated into the main body.
5. Do not reuse tip that has been used once, and carefully dispose used tip. If tip is used repeatedly, it may cause inaccurate and impure pipetting and cross contamination (\*) among samples.
  - \* For example, if previous sample liquid is left inside tip, it is mixed with new sample liquid and the new sample is contaminated by the previous one. Therefore, pipetting of the next sample results wrong. This phenomenon is called mutual contamination of samples.
5. Do not hold pipette horizontally or upside down when there is liquid inside tip, otherwise the liquid gets into the main body and the pipette may be contaminated.
6. Do not perform pipetting with less liquid than set volume. If the quantity of liquid is less than the set volume, it may cause the liquid to scatter into the main body and the pipette may deteriorate in quality.

Contents

Operating procedure .....5  
Disassembling/Reassembling the airtight chamber .....6  
Service And Maintenance Information .....6  
Disassembly .....6  
Filter replacement procedure .....8  
Specification .....9  
Ordering Information ..... 10  
Troubleshooting ..... 11

## Operating procedure

1. Select the desired volume on Nichipet V II by turning the thumb knob until the desired volume figures on the thumb knob correspond to the arrow mark printed on the top of the pipette handle. (Fig. 1)
2. Place a disposable tip firmly onto the end of the pipette. Depress the thumb knob to the first stop. Dip the tip into the liquid to a depth of 3mm. (Step 1 of Fig. 2)
3. Smoothly return the thumb knob to its original position. The liquid will then be drawn into the tip. (Step 2)

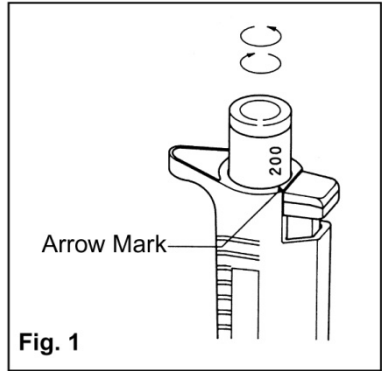

4. Touch the tip against the inside wall of the receiving vessel. (Step 3)
5. Smoothly depress the thumb knob to the first stop (step 4), pause: then depress the knob to the second stop (step 5).

**Note:** When dispensing serum and other viscous fluids, it is necessary to pause about two seconds before moving to the secondary stop.

6. Remove the used tip from the pipette by depressing the tip ejector knob. (Step 6)

**Note:** Depress and release the thumb knob at constant speed to ensure good precision.

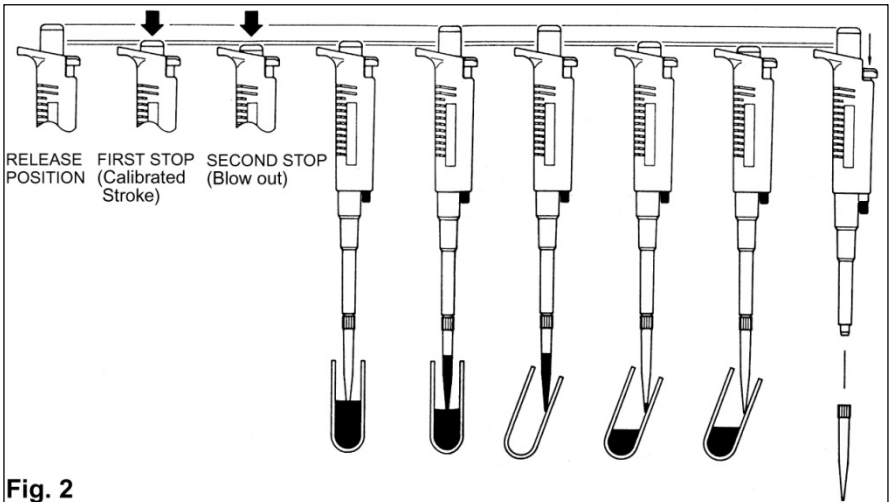

## Disassembling/Reassembling the airtight chamber

Listed below are some techniques found to improve sampling precision.  
PLEASE READ THIS SECTION CAREFULLY.

1. Try to effect the same speed for both the intake and delivery of all samples. Smooth depression and release of the plunger knob will give the most consistent results. Never allow the plunger to “snap” back. Consistency of technique is a key to precision.
2. Always depress the thumb knob to the proper stop before insertion of the tip into the solution. Depression of the thumb knob after insertion may cause the formation of an air bubble in the tip and result in filling error.
3. Try to insert the tip to approximately the same depth in the sample each time, never going deeper than 3mm. Hold the instrument as vertically as possible (10° maximum from vertical).
4. When sampling hot or cold material, the tip temperature should be equalized to that of the solution to prevent contraction or expansion of solution.

## Service And Maintenance Information

It is recommended that the following servicing procedures be performed at regular intervals. Heavy usage or usage with corrosive fluids will require more frequent servicing.

### Disassembly (Reference Figure 3 & 4)

1. Turn the screw bolt counterclockwise to remove a tip ejector pipe. Gently pull the tip ejector pipe off the end of tip ejector pipe during this procedure.
2. Unscrew the barrel assembly from the handle and carefully pull directly away from the handle. The plunger assembly and spring can be removed from the pipette. Refer to Figure 4 for the internal configuration of the pipette being serviced. Take special care not to bend the piston rod, especially in the smaller volume units.
3. Replace the O-ring.

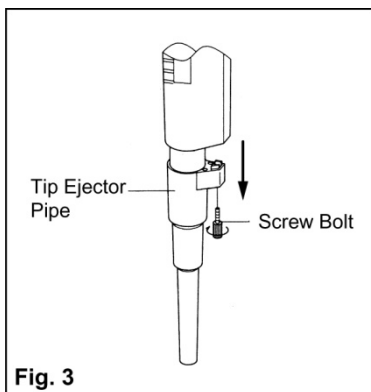

4. Reassemble the unit by reversing the above procedures. Refer to Figure 4 when reassembling to ensure that all parts are placed in the correct position.
5. To reassemble the tip ejector pipe gently push on the tip ejector pipe so that the pipe mates with the handle connection. Turn the screw clockwise to secure.
6. After the above maintenance procedure, should the feeling of a smooth piston stroke seem different from what it was before this procedure, immediately disassemble the pipette as in the above procedure and reassemble per the schematics in Figures 3 and 4.
7. After the above maintenance procedure, should the tip ejector knob stroke seem different and lack the smoothness of its normal stroke, immediately disassemble the tip ejector portion of the pipette and reassemble ensuring the spring and spring holder are installed properly.

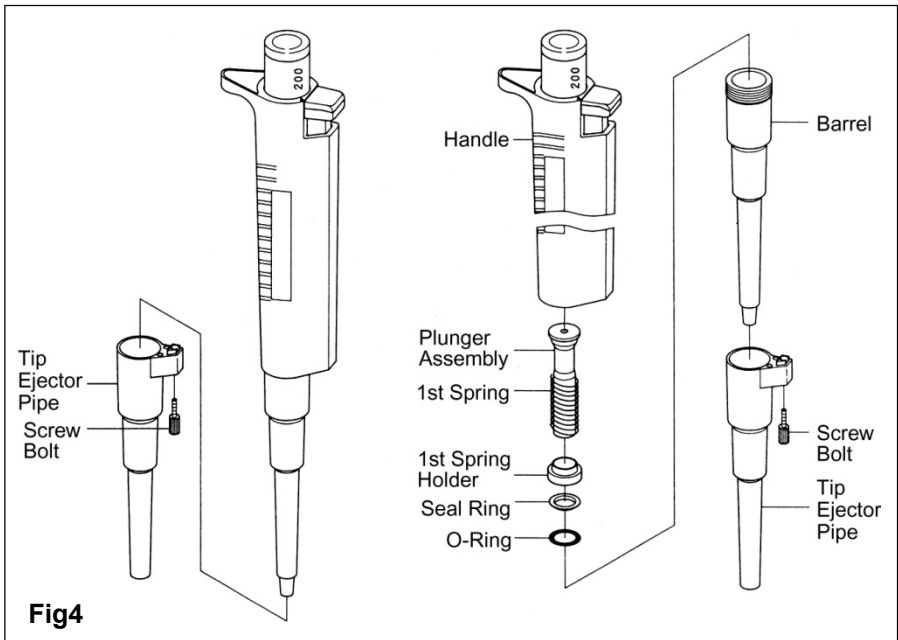



**Fig.5**

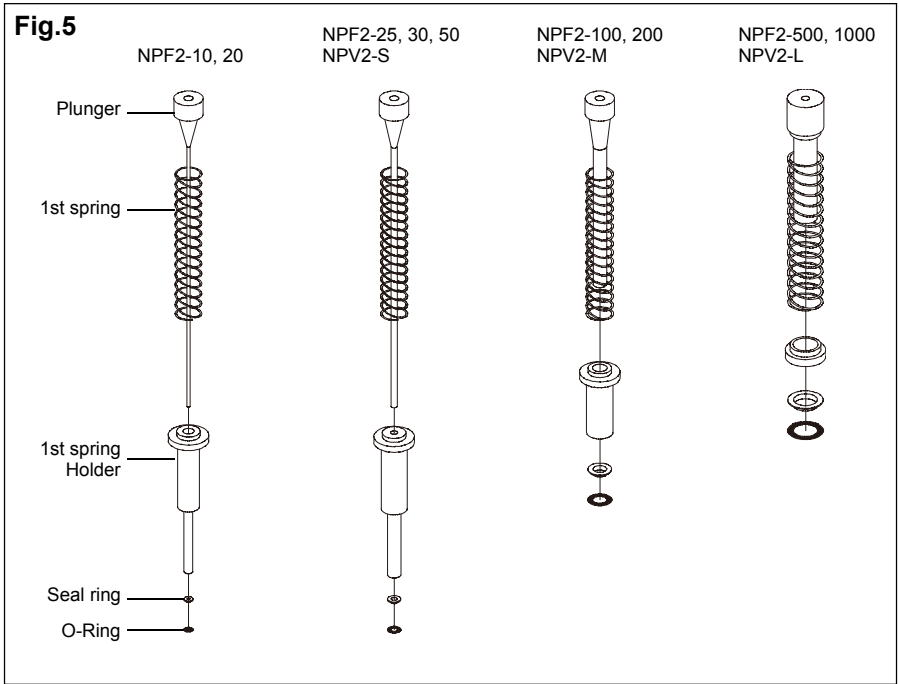

### Filter replacement procedure

NPF2-500,1000,NPV2-L: Fig. 6

- ① Insert the tips of filter remover into two notches on the sides of a filter, and pull out the filter in the direction of the arrow.
- ② Set the projection of a new filter in the internal groove of the nozzle, and then press the filter into the nozzle.



**Do not touch filters which may be contaminated by harmful substances.**

**Fig.6**

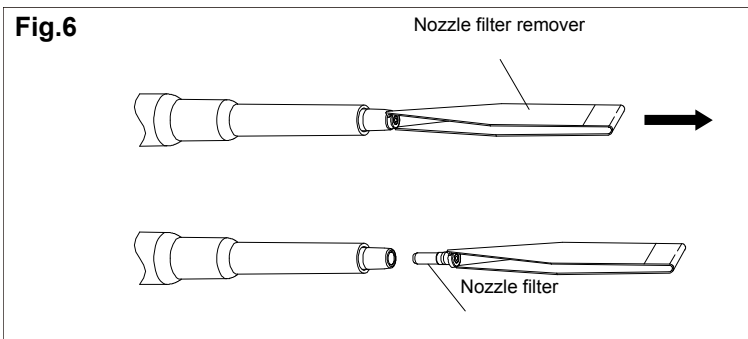

## Specifications

Cat.No.	Vol. Setting	Volume ( $\mu\text{L}$ )	Accuracy (%)	Precision (%)
00-NPF2-10	Fixed	10	$\pm 1.2$	$\leq 0.4$
00-NPF2-20	Fixed	20	$\pm 0.8$	$\leq 0.3$
00-NPF2-25	Fixed	25	$\pm 0.8$	$\leq 0.3$
00-NPF2-30	Fixed	30	$\pm 0.8$	$\leq 0.3$
00-NPF2-50	Fixed	50	$\pm 0.6$	$\leq 0.3$
00-NPF2-100	Fixed	100	$\pm 0.6$	$\leq 0.3$
00-NPF2-200	Fixed	200	$\pm 0.6$	$\leq 0.2$
00-NPF2-500	Fixed	500	$\pm 0.5$	$\leq 0.2$
00-NPF2-1000	Fixed	1000	$\pm 0.5$	$\leq 0.2$
00-NPV2-S	Three variable setting	10	$\pm 1.2$	$\leq 0.6$
		20	$\pm 1.0$	$\leq 0.5$
		50	$\pm 0.7$	$\leq 0.3$
00-NPV2-M	Three variable setting	50	$\pm 0.7$	$\leq 0.4$
		100	$\pm 0.6$	$\leq 0.4$
		200	$\pm 0.5$	$\leq 0.3$
00-NPV2-L	Three variable setting	200	$\pm 0.7$	$\leq 0.3$
		500	$\pm 0.6$	$\leq 0.3$
		1000	$\pm 0.5$	$\leq 0.2$

The technical figures given in the Table-1 "Nichipet FII VII Maximum Permissible Errors" were obtained using genuine Nichiryo BMT Tips.

Nichiryo declares that pipettes comply with the requirement of the ISO 8655 Standard, by type testing. The adjustment is carried out under strictly defined and monitored conditions (ISO 8655-6):

- The basis of adjustment, EX
- Reference temperature, 20°C-25°C
- Relative humidity, more than 50%
- Barometric pressure, 101KPa,
- Use of distilled water, distilled water

## Ordering Information

### Nichipet-F II Fixed Volume Pipette

Cat.No.	Volume( $\mu$ L)	Accessories
00-NPF2-10(10 $\mu$ L) to 00-NPF2-1000(100 $\mu$ L)	10,20,25,30,50 100,200,500,1000	Appropriate tips

### Nichipet-V II TRIPLE VOLUME

Cat.No.	Volume( $\mu$ L)	Accessories
00-NPV2-S	10/20/50	Appropriate tips
00-NPV2-M	50/100/200	
00-NPV2-L	200/500/1000	

### Tip (Autoclavable)

Cat.No.	Volume( $\mu$ L)	Color	Usable Model	Q'ty(bag)
00-BMT2-SS	0.5 ~ 10	Natural	NPF2-10	1000pcs
00-BMT2-SG	2 ~ 200	Natural	NPF2-20 ~ 200 NPV2-S,M	1000pcs
00-BMT2-LG	100 ~ 1000	Natural	NPF2-500,1000 NPV2-L	1000pcs

### Racked Tip (Autoclavable)

Cat.No.	Volume( $\mu$ L)	Color	Usable Model	Q'ty(box)
00-BMT2-SSR	0.5 ~ 10	Natural	NPF2-10	960pcs (96pcs.x10c/s)
00-BMT2-SGR	2 ~ 200	Natural	NPF2-20 ~ 200 NPV2-S,M	960pcs (96pcs.x10c/s)
00-BMT2-LGR	100 ~ 1000	Natural	NPF2-500,1000 NPV2-L	960pcs (96pcs.x10c/s)

### Stand

Cat.No.	Description
00-BMT-STD (Acryl resin)	6 pipettes can be stored.

## Troubleshooting

Symptom	Possible cause	Remedy
Tip cannot be ejected.	Nozzle cylinder loosens	Tighten up the nozzle cylinder securely.
Pipette fails to aspirate liquid.	Seal ring and O-ring are assembled in reverse order.	Reset the seal ring and O-ring set according to the manual in "Disassembling /reassembling".
	Seal ring or/and O-ring set are worn.	Replace an seal ring and O-ring set.
Extracted liquid leaks from tip.	Nozzle cylinder loosens	Tighten up the nozzle cylinder securely.
	Nozzle cylinder is worn (stepped wear can be checked by eye).	Replace an nozzle cylinder.
	Seal ring and O-ring set is worn because the plunger is damaged or rusty.	Replace an seal ring and O-ring set.
	The tip is loosely attached.	Replace an seal ring and O-ring set.
Push button moves stiffly.	The tip is loosely attached.	If the push button does not work well after dispensing, or it is sticking to the body, disassemble the pipette and wash/clean every part (or wipe down every part with soft cloth). If there are some parts getting rusty or corroded inside the body, replace the parts with new ones.



**If the pipette can not be fixed after examining and conducting the above mentioned procedure, immediately stop using the pipette and ask us or our agent to repair it.**

**Before bring the pipette for repair, be sure to check whether it has been contaminated with microbes or harmful substance.**

# Memo

# Memo

# Memo

For repair, service or information you may contact your local distributor.

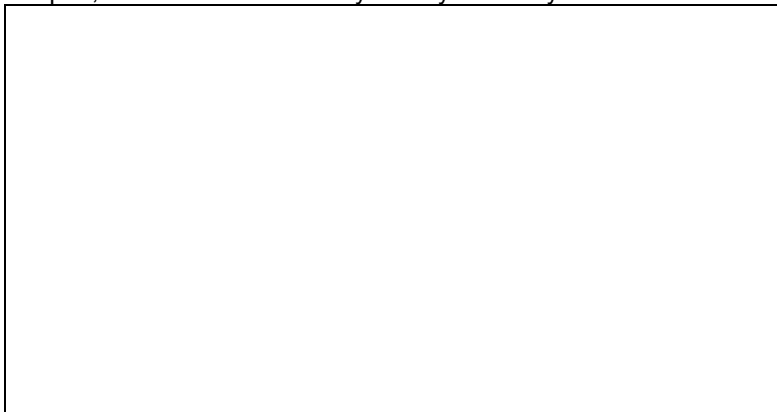

**MANUFACTURER:**

**NICHIRYO CO.,LTD.**

Tokyo office

1-10-1 Kandnishiki-cho, Chiyoda-ku, Tokyo 101-0054, Japan

TEL: +81-3-6273-7652(English) FAX: +81-3-6273-7944

URL: <http://www.nichiryoko.co.jp/>

E-mail: [i-sales@nichiryoko.co.jp](mailto:i-sales@nichiryoko.co.jp)