

DISPET MINI

Micro dispenser, dual volume

Operating Manual

Vendor

NICHIRYO CO.,LTD.

Website

<https://www.nichiryo.co.jp/en/>

Email

info@nichiryo.co.jp

●For inquiries, please use the contact form on our website or send us an email.

SB-DPM001EN

Before using the instrument for the first time, ensure it is rinsed carefully or discard the first few samples dispensed.



Contents

1. Safety Instructions	3
2. Application and Operating Limitations	4
3. Operating Exclusions	4
4. Operating Limitations	5
5. Components	6
6. Dispensing	7
6.1. Preparation for dispensing	7
6.2. Priming	7
6.3. Adjusting the volume	7
6.4. Dispensing	7
7. Cleaning	8
7.1. Emptying	8
7.2. Standard cleaning	8
7.3. Intensive cleaning	9
8. Cleaning/replacing the valves	10
8.1. Intake valve	10
8.2. Discharge valve	10
9. Calibration	11
10. Troubleshooting	12
11. Repair service	13
12. Warranty	13
13. Technical Data/ Ordering Information	14
13.1. Items supplied	14
13.2. Accessories and Spare Parts	15

13.2 Accessories and Spare Parts

Intake tube, length 150 mm	1650010
Intake valve complete with ball (ETFE/Borosilicate glass)	1655011
Discharge tube	1650145
Discharge valve (PFA/Borosilicate glass/ Platinum-Iridium)	1655090
Threaded bottles, 100 ml, coated, GL28	1671505

13. Technical data / Ordering information

13.1 Items supplied

DISPET MINI complete with
discharge tube, intake tube and tool, GL 28

Volume	Systematic error* A%	Random error* CV%	Cat. No.
100/250 µl	≤ ± 2,0	≤ 0,4	1611503
500/1000 µl	≤ ± 1,0	≤ 0,2	1611506
1000/2000 µl	≤ ± 1,0	≤ 0,2	1611508

* Values based on nominal volume.

Calibration conditions:

Distilled water delivered at,
20 ± 0.5 °C

Number of testing procedures:

10 according to
DIN EN ISO 8655

(Technical specifications subject
to change!)

1. Safety Instructions

This Manual does not purport to address every safety issue which may arise during use. It is the responsibility of whomever uses this instrument to consult and establish appropriate safety and health practices and determine the applicability of regulatory limitations prior to use.

1. Use the utmost caution when dispensing caustic, poisonous, radioactive or hazardous chemicals.
2. Observe general safety regulations (e.g., wear protective clothing, goggles and gloves).
3. Observe the Operating Manual and information from reagent manufacturers.
4. Use the instrument only for dispensing liquids, with strict regard to the defined Operating Exclusions and Limitations. If in doubt regarding the suitability of the instrument, for a particular application contact the manufacturer.
5. Before use, always verify that the instrument is in good working order, e.g., piston moves smoothly; filling and discharge tubes are firmly seated and are properly attached, etc
6. Never use force on the instrument. Use of force may result in injury to the user or other persons.
7. While dispensing, the discharge tube must always point away from the user or other persons. Avoid splashes. Only dispense into suitable vessels.
8. Clean the instrument before disassembling.
9. Use only original manufacturer's accessories and spare parts. Do not carry out any technical alterations.
10. In case of difficulty (e.g., piston difficult to move, leakage), immediately stop dispensing. Before further use, repair the instrument as described in this Manual. Contact the manufacturer if necessary.

2. Application and Operating Limitations

This instrument is designed for dispensing liquids, observing the following physical limits:

- 15 to 40 °C for instrument and reagent
- density up to 2.2 g/cm³
- vapor pressure up to 500 mbar
- viscosity up to 200 mm²/s

3. Operating Exclusions

When the instrument is correctly used, the dispensed liquid comes into contact with only the following materials: Borosilicate glass, FEP, ETFE, PFA, PTFE, Platinum-Iridium and PVDF (closure cap).

The instrument is suitable for dispensing a wide range of liquids, **excluding**:

- Liquids which attack FEP, ETFE, PFA, PTFE and PVDF;
- Solutions containing hydrofluoric acid, since they attack borosilicate glass;
- Suspensions, containing solid particles;
- Solutions which decompose and form solid particles (e.g., Biuret reagent);
- Substances which undergo catalytic transformation or react with Platinum-Iridium (e.g., H₂O₂);
- Carbon disulfide

11. Repair Service

Attention!

Only cleaned and decontaminated instruments can be evaluated/ repaired.

Clean and decontaminate the instrument thoroughly. Return instrument along with a description of the malfunction and dispensed liquids.

12. Warranty

We shall not be liable for the consequences of improper handling, use, servicing or unauthorized repairs of the instrument or the consequences of normal wear and tear especially of wearing parts such as pistons, seals, valves and the breakage of glass as well as the failure to follow the instructions of the operating manual. We are not liable for damage resulting from any actions not described in the operating manual or if non-original parts have been used.

10. Troubleshooting

Trouble	Possible causes	Action to be taken
Piston is difficult to move	Formation of crystals	Clean instrument (see chapter 7)
Reagent is not aspirated	Sticking filling valve	Clean intake valve; replace if necessary (see chapter 8.1)
Cylinder does not fill	Discharge valve damaged	Clean discharge valve; replace if necessary (see chapter 8.2)
Intake-/discharge tube not firmly connected	Tubes damaged	Replace intake-/discharge tube
Air is aspirated	Intake valve not firmly connected	Tighten intake valve; replace if necessary (see chapter 8.1)
	Intake tube not firmly connected or damaged	Push intake tube on firmly; replace if necessary
	Reagent with high vapor pressure has been drawn in too quickly	Aspirate reagent more slowly
Dispensed volume is too low	Intake valve leaks	Clean intake valve; replace if necessary (see chapter 8.1)
	Intake tube not firmly connected or damaged	Push intake tube on firmly; replace if necessary

If these measures do not help, return instrument for repair (see chap. 11).

4. Operating Limitations

Liquids which form deposits may make the piston difficult to move or may cause jamming (e.g., crystallizing solutions or highly concentrated alkaline solutions).

When dispensing flammable media, make provisions to avoid static charging, e.g., do not dispense into plastic vessels; do not wipe instruments with a dry cloth.

Warning!

If there is a sign of a potential malfunction (e.g., piston difficult to move) never use force. Immediately stop dispensing and follow cleaning instructions (see chapter 7) or contact the manufacturer.

Note:

Compatibility of the instrument for this special application (e.g., trace material analysis) must be checked by the user or contact the manufacturer.

5. Components

1. Handle
2. Outer sleeve
3. Securing ring
4. Operating knob
5. Piston
6. Lifting spring
7. Glass cylinder
8. Valve head (GL 28)
9. Valve ball
10. Intake valve
11. Intake tube
12. Discharge tube support
13. Securing clip
14. Discharge valve
15. Discharge tube securing nut
16. Discharge tube
17. Valve tool

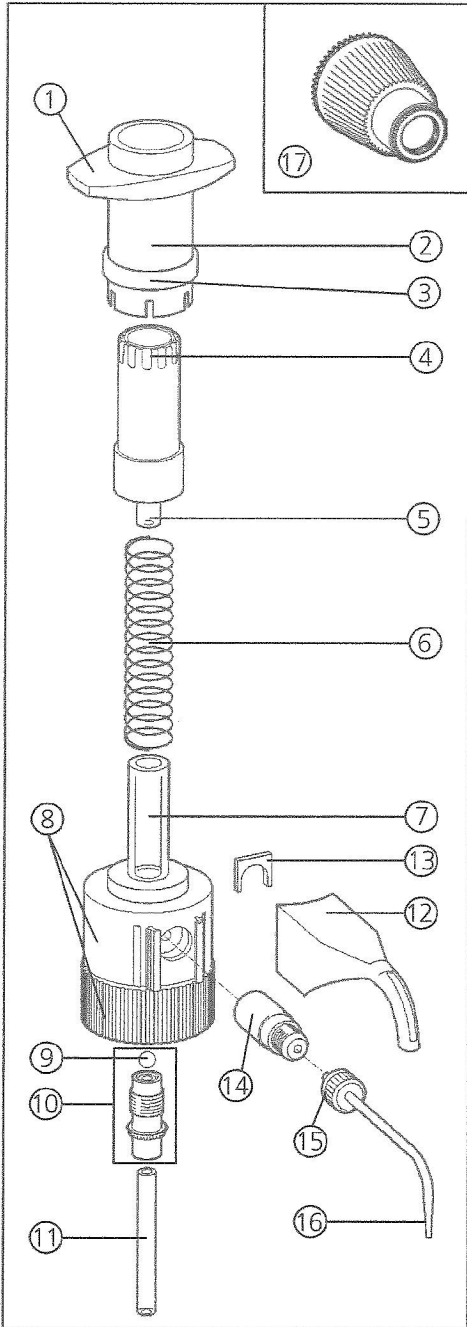

9. Calibration

The procedure is described in detail in DIN EN ISO 8655/6

1. Set instrument to nominal volume and dispense distilled water into a weighing vessel.
2. Weigh the dispensed amount of water with an analytical balance.
3. Convert the indicated weight into volume units, taking into account the temperature, density and atmospheric pressure. (The conversion factor Z is published in the standard.)
4. Carry out 10 dispensing procedures.
5. Calculate systematic error (A%) and random error (R%).

8. Cleaning/replacing the valves

8.1. Cleaning/replacing the intake valve

Note:

Valve ball (9) may fall out when valve is removed.

1. Unscrew the intake valve (10) using the valve tool (17).
2. Clean or replace the valve.
3. Make sure that valve ball is still in place. To reassemble, handtighten valve (10) and complete using valve tool (17).

8.2. Cleaning/replacing the discharge valve

1. Remove the discharge tube support (12). Pull out securing clip (13) with a small screwdriver.
2. Pull out the discharge valve (14).
3. Unscrew the discharge tube securing nut (15) and pull out the discharge tube (16).
4. Clean or replace the valve.
5. To reassemble push in valve (14) by hand and insert securing clip (13).
6. Push in the discharge tube as far as possible and tighten the securing nut (15).
7. In reverse order mount the discharge tube support (12).

Warning!

Never use force during disassembly and assembly. Verify that all components fit tightly and securely. Subsequent to reassembly, gravimetrically check volume (see chapter 9).

6. Dispensing

6.1. Preparation for dispensing

1. Observe Operating Limitations and general safety regulations.
2. Push the intake tube into the intake valve as far as possible and cut the lower end at an angle.
3. Screw the dispenser on to the reagent bottle and align it with the bottle label.

Warning!

Avoid splashing of reagent!

4. Place a suitable vessel below the discharge tube.
5. The discharge tube must point away from the user at all times.

6.2. Priming

1. Place a suitable vessel below the discharge tube.

Warning!

Reagent may splash!

2. Gently push down the piston several times until air bubbles have disappeared from the discharge tube.

6.3. Adjusting the volume

Warning!

Reagent will dispense while volume is being adjusted. Hold a suitable vessel below the discharge tube outlet.

To set the volume, push down the operating knob and twist handle 90°. The nose of the housing indicates the volume after releasing operating knob.

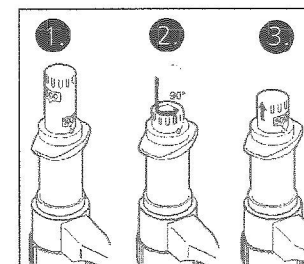

6.4. Dispensing

1. Place a suitable vessel below the discharge tube.
2. Slowly steadily depress piston, release gently. No air bubbles should be visible during dispensing.

Warning!

If the piston moves stiffly or is difficult to move, stop dispensing immediately and clean the instrument (see chap. 7).

Attention!

Reagent may escape from the discharge tube.

7. Cleaning

Instrument will only function safely if cleaned regularly. Be sure to clean the instrument:

1. Immediately, if the piston moves stiffly;
2. Before changing reagents
3. Before longer breaks in use
4. Before any maintenance and repair work

Warning!

Dispenser, intake tube and discharge tube may be filled with reagent. To prevent injury from chemicals, always wear eye protection, protective clothing and protective gloves. Always point the discharge tube outlet away from the user or other people.

7.1. Emptying

1. While the dispenser is still mounted on the bottle, place into a suitable basin.
2. Unscrew the dispenser and lift it high enough so that the intake tube is no longer immersed in liquid.
3. Cautiously tap the intake tube against the inside of the bottle so that any remaining reagent runs out.

4. Remove the dispenser from the bottle and mount it on another empty bottle.
5. Hold the discharge tube outlet over the opening of the first bottle. Empty the discharge tube by repeated dispensing movements.

7.2. Standard cleaning

1. Mount the empty dispenser on a bottle filled with a suitable cleaning solution.

Warning!

Reagent may splash!

2. Rinse the dispenser by repeated dispensing movements. Place a suitable vessel below the discharge tube.
3. Completely empty the instrument by repeated dispensing movements, as described in chapter 7.1.
4. Mount the dispenser on a bottle filled with distilled water and rinse it by repeated dispensing movements. Then empty the instrument as described in chapter 7.1.

7.3. Intensive cleaning

Intensive cleaning must be preceded by a standard cleaning. This procedure must be followed if the piston is difficult to move. For this purpose, the dispenser must be partially disassembled.

Warning!

Before disassembling, always perform the standard cleaning procedure. To prevent injury from chemicals, always wear eye protection, protective clothing and protective gloves. Avoid splashing of reagent.

1. Pull off the intake tube (11) and clean it with a soft bottle brush. Replace if necessary, especially if cracked or worn.
2. Use a small screw driver to gently pry between the securing ring slot (3) and valve head (8) and carefully push up the securing ring (3).
3. Disassemble outer sleeve (2) by pressing down operating knob (4) and pulling the securing ring (3) simultaneously.
4. Remove the operating knob (4) with the piston (5) and the "Lifting spring".

5. Clean the piston and the cylinder with a soft bottle brush and rinse with water.

Attention!

Insert the piston at a slight angle to avoid damage to the lip seal.

6. Mount the lifting spring (6) and carefully reinsert the piston (5).
7. Replace the outer sleeve (2) and press it down until it audibly locks in place.
8. Push down the securing ring (3).