DISPET EX II

Bottle Top Dispenser

Operating Manual





Table of Contents

| | |
|---|----|
| 1. Safety Instructions | 4 |
| 2. Functions and Limitations of Use | 5 |
| 3. Dispenser Selection Chart | 6 |
| 4. Operating Elements | 7 |
| 5. First Steps | 8 |
| 6. Priming | 10 |
| 7. Dispensing | 11 |
| 8. Accessories | 12 |
| 9. Error Limits (Nominal Volume - Partial Volume) | 14 |
| 10. Checking the Volume (Calibration) | 15 |
| 11. Adjustment | 16 |
| 12. Cleaning | 17 |
| 13. Replacement of discharge tube/ valves | 19 |
| 14. Autoclaving | 21 |
| 15. Ordering Information | 22 |
| 16. Accessories and Spare Parts | 23 |
| 17. Troubleshooting | 26 |
| 18. Repairs - Contact addresses | 27 |
| 19. Warranty Information | 28 |
| 20. Disposal | 28 |

1. Safety Instructions

This instrument may sometimes be used with hazardous materials, operations, and equipment. It is beyond the scope of this manual to address all of the potential safety risks associated with its use in such applications. It is the responsibility of the user of this instrument to consult and establish appropriate safety and health practices and determine the applicability of regulatory limitations prior to use.

 Please read the following carefully!

1. Every user must read and understand this operating manual before operation.
2. Follow general instructions for hazard prevention and safety instructions; e.g., wear protective clothing, eye protection and gloves.
3. Observe all specifications provided by reagent manufacturers.
4. When dispensing inflammable media, make sure to avoid the buildup of static charge, e.g., do not dispense into plastic vessels; do not wipe instruments with a dry cloth.
5. Use the instrument only for dispensing liquids, with strict regard to the defined limitations of use and operating limitations. Observe operating exclusions (see page 5)! If in doubt, contact the manufacturer or supplier.
6. Always use the instrument in such a way that neither the user nor any other person is endangered. When dispensing, the discharge tube must always point away from you or any other person. Avoid splashes. Only use suitable vessels.
7. Never press down the piston when the closure cap is attached.
8. Never remove the discharge tube while the dispensing cylinder is filled.
9. Reagents can accumulate in the closure cap of the discharge tube. Thus, the closure cap should be cleaned regularly.
10. For small bottles, and when using the flexible discharge tube, use a bottle stand to prevent tipping over.
11. Never carry the mounted instrument by the cylinder sleeve or the valve block. Breakage or loosening of the cylinder may also lead to personal injury from chemicals (see page 9, Fig. 3).
12. Never use force on the instrument. Use smooth gentle movements to operate the piston upwards and downwards.
13. Use only original manufacturer's accessories and spare parts. Do not attempt to make any technical alterations. Do not dismantle the instrument any further than is described in the operating manual!
14. Always check the instrument for visible damage before use. If there is a sign of a potential malfunction (e.g., piston difficult to move, sticking valves or leakage), immediately stop dispensing. Consult the 'Troubleshooting' section of this manual (see page 26), and contact the manufacturer if needed.

2. Functions and Limitations of Use

With bottle-top dispensers, liquids can be dispensed directly from the supply bottle. Available in variable models.

The instruments are, according to the requirements of the DIN EN ISO 8655-5, marked DE-M.

When the instrument is correctly used, the dispensed liquid comes into contact with only the following chemically resistant materials: Borosilicate glass, Al₂O₃-ceramic, ETFE, FEP, PFA, PTFE, platinum-iridium, PP (closure cap). If a higher chemical resistance is required, please use a ETFE/PTFE bottle adapter ('Accessories', pages 23).

Limitations of Use

This instrument is designed for dispensing liquids, observing the following physical limits:

- use temperature from +15 °C to +40 °C (from 59 °F to 104 °F) of instrument and reagent
- vapor pressure up to max. 600 mbar. Aspirate slowly above 300 mbar, in order to prevent the liquid from boiling.
- kinematic viscosity up to 500 mm²/s (dynamic viscosity [mPas] = kinematic viscosity [mm²/s] x density [g/cm³])
- Density up to 2.2g/cm³

Operating Exclusions

Dispenser never use with:

- liquids attacking Al₂O₃-ceramic, ETFE, FEP, PFA and PTFE (e.g., dissolved sodium azide*)
- liquids attacking borosilicate glass (e.g., hydrofluoric acid)
- liquids which are decomposed catalytically by platinum-iridium (e.g., H₂O₂)
- nitric acid > 60%
- tetrahydrofuran
- trifluoroacetic acid
- explosive liquids (e.g., carbon disulfide)
- suspensions (e.g., of charcoal) as solid particles may clog or damage the instrument
- liquids attacking PP (closure cap)**

* Dissolved sodium azide permitted up to a concentration of max. 0.1%.

** When stronger chemical resistance is needed, use the ETFE/PTFE adapter (Accessories, page 23)

Operating Limitations

Liquids, which form deposits may make the piston difficult to move or may cause jamming (e.g., crystallizing solutions or concentrated alkaline solutions). If the piston movement becomes sluggish or stiff, the instrument should be cleaned immediately (page 17).

When dispensing inflammable media, make sure to avoid to buildup of static charge, e.g., do not dispense into plastic vessels; do not wipe instruments with a dry cloth.

The instrument is designed for general laboratory applications and complies with the relevant standards, e.g. DIN EN ISO 8655. Compatibility of the instrument for a specific application (e.g., trace material analysis, food sector etc.) must be checked by the user. Approvals for specific applications, e.g. for production and administration of food, pharmaceuticals or cosmetics are not available.

Storage Conditions

Store the instrument and accessories only in cleaned condition in a cool and dry place. Storage temperature: from -20°C to +50 °C

(from -4 °F to 122 °F).

3. Recommended Application Range

The dispenser broad range of application permits bottle dispensing of aggressive reagents, including concentrated acids such as H₃PO₄, bases like NaOH, KOH, saline solutions, as well as many organic solvents. Please observe the Operating Exclusions and the 'Application Range'.

| Reagent | Reagent | Reagent |
|---------------------------------|--|---|
| O Acetaldehyde | O m-Cresol | O Methyl formate |
| O Acetic acid, ≤ 96 % | O Cumene (isopropylbenzene) | O Methyl propyl ketone |
| O Acetone | O Cyclohexanone | O Mineral oil (motor oil) |
| O Acetonitrile | O Decane | O Monochloroacetic acid, 50% |
| O Acetylacetone | O 1-Decanol | I Nitric acid, ≤ 60%* ** |
| O Acrylic acid | O Di(ethylene glycol) | O Nitrobenzene |
| O Acrylonitrile | O Dibenzyl ether | O Octane |
| O Adipic acid | O Dichlorobenzene | O Oleic acid |
| O Allyl alcohol | O Dichloroethane | O Oxalic acid |
| I Aluminium chloride | O Dichloromethane | I Perchloric acid |
| O Amino acids | O Diethanolamine | O Petroleum |
| I Ammonia solution, ≤ 20 % | O Diethyl ether | O Phenol |
| I Ammonium chloride | O Diethylamine | O Phenylethanol |
| I Ammonium fluoride | O 1,2 Diethylbenzene | O Phenylhydrazine |
| I Ammonium hydroxide, ≤ 20 % | O Dimethyl sulphoxide (DMSO) | I Phosphoric acid, ≤ 85% |
| I Ammonium sulphate | O Dimethylaniline | I Phosphoric acid, 85% + sulphuric acid, 98%,1:1 |
| O Amyl acetate | O Dimethylformamide (DMF) | O Piperidine |
| O Amyl alcohol (pentanol) | O 1,4 Dioxane | I Potassium chloride |
| O Amyl chloride (chloropentane) | O Diphenyl ether | I Potassium dichromate |
| O Aniline | O Ethanol | I Potassium hydroxide |
| I Barium chloride | O Ethanolamine | I Potassium permanganate |
| O Benzaldehyde | O Ethyl acetate | O Propanol |
| O Benzene | O Formaldehyde, ≤ 40 % | O Propionic acid |
| O Benzoyl chloride | O Formamide | O Propylene glycol (propanediol) |
| O Benzyl alcohol | O Formic acid, ≤ 100 % | O Propylene oxide |
| O Benzyl chloride | O Gasoline | O Pyridine |
| O Benzylamine | O Glacial acetic acid (acetic acid), 100 % | O Pyruvic acid |
| I Boric acid, ≤10 % | O Glycerine | O Salicylaldehyde |
| O Bromobenzene | O Glycol (ethylene glycol) | O Salicylic acid |
| O Bromonaphthalene | O Glycolic acid, ≤ 50% | O Silver acetate |
| O Butanediol | O Heating oil (Diesel oil) | I Silver nitrate |
| O 1-Butanol | O Hexane | O Sodium acetate |
| O n-Butyl acetate | O Hexanoic acid | I Sodium chloride |
| O Butyl methyl ether | O Hexanol | I Sodium dichromate |
| O Butylamine | I Hydrochloric acid, ≤ 37%** | I Sodium fluoride |
| O Butyric acid | I Hydroiodic acid, ≤ 57 %** | I Sodium hydroxide, ≤ 30% |
| I Calcium carbonate | I Iodine / potassium iodide solution | I Sodium hypochlorite |
| I Calcium chloride | O Isoamyl alcohol | I Sulphuric acid, ≤ 98% |
| I Calcium hydroxide | O Isobutanol | O Tartaric acid |
| I Calcium hypochlorite | O Isopropanol (2-propanol) | O Tetramethylammonium hydroxide |
| O Chloroacetaldehyde, ≤ 45 % | O Isopropyl ether | O Toluene |
| O Chloroacetic acid | O Lactic acid | O Turpentine |
| O Chloroacetone | I Magnesium chloride | O Urea |
| O Chlorobenzene | I Mercury chloride | O Xylene |
| O Chlorobutane | O Methanol | I Zinc chloride, ≤ 10 % |
| O Chloronaphthalene | O Methoxybenzene | I Zinc sulphate, ≤ 10 % |
| I Chromic acid, ≤ 50 % | O Methyl benzoate | |
| I Chromic-sulphuric acid | O Methyl butyl ether | |
| I Copper sulphate | O Methyl ethyl ketone | |

* use ETFE/PTFE bottle adapter
** use drying tube

The above recommendations reflect testing completed prior to publication. Always follow instructions in the operating manual of the instrument as well as the reagent manufacturer's specifications. In addition to these chemicals, a variety of organic and inorganic saline solutions (e.g., biological buffers), biological detergents and media for cell culture can be dispensed. Please call us if you need information on chemicals that are not named in the list. Status as of: 10/15

| |
|-----------------------|
| A Organic solutions |
| O Inorganic solutions |

4. Operating Elements

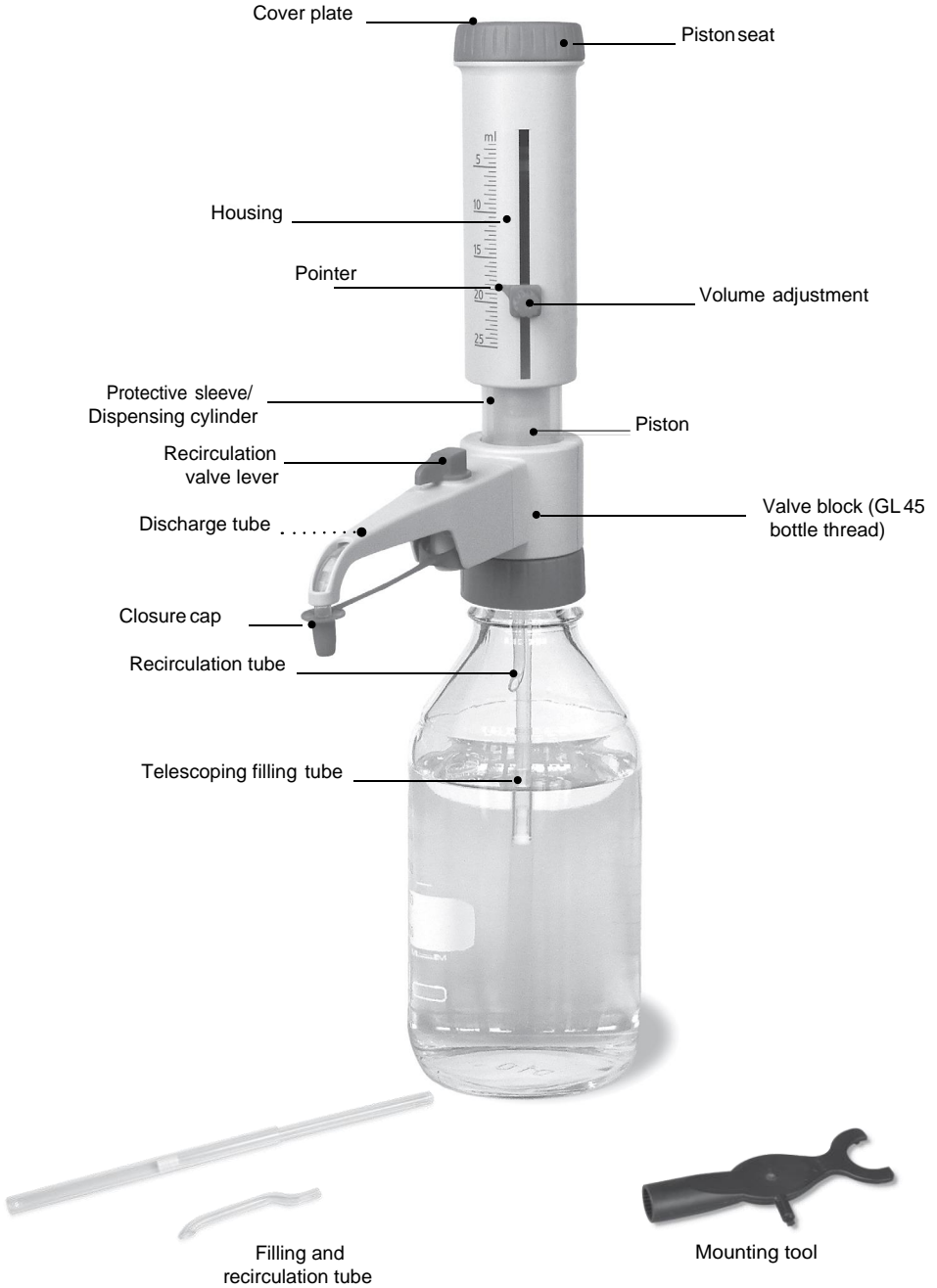

5. First Steps

5.1 Is everything in the package?

Confirm that your package includes:

Bottle-top dispenser with discharge tube with recirculation valve, telescoping filling tube, recirculation tube, mounting tool, bottle adapters, a performance certificate and this operating manual

| Nominal volume, ml | Adapters for bottle thread, PP | Filling tube Length, mm |
|--------------------|---------------------------------------|-------------------------|
| 1, 2, 5, 10 | GL 25, GL 28/S 28, GL 32, GL 38, S 40 | 125-240 |
| 25, 50, 100 | GL 32, GL 38, S 40 | 170-330 |

5.2 Assembly

Warning!

Wear protective clothing, eye protection and gloves! Follow all safety instructions and observe limitations of use and operating limitations (page 4-6).

1. Mounting the filling tube/ recirculation tube

Adjust the length of the telescoping filling tube to the bottle height and attach it. Center and attach the filling tube carefully to avoid damaging the nozzle. Also install the recirculation tube. Insert it with the opening pointing outward (Fig. 1).

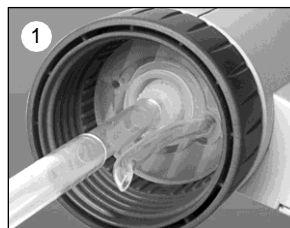

2. Mounting the instrument on a bottle and alignment

Screw the instrument (GL 45 threads) onto the reagent bottle, and then align the discharge tube with the bottle label. This is done by rotating the valve block with the discharge tube (Fig. 2).

To avoid tipping over, use a bottle stand for small bottles.



5.2 Assembly (continued)

Note:

For bottles with other thread sizes, select a suitable adapter. The adapters supplied with the instrument are made of polypropylene (PP), and can only be used for media which do not attack PP.

Alternatively ETFE/PTFE bottle adapters can be used (‘Accessories’, page 22). The suitability of ETFE/PTFE bottle adapters must be checked by the user.

Warning!

Always wear protective gloves when touching the instrument or the bottle, especially when using dangerous liquids.

When mounted to a reagent bottle, always carry the instrument as shown in figure 3!



6. Priming

Warning!

Wear protective clothing, eye protection and gloves! Never press down the piston when the closure cap is put on! Avoid splashing the reagent! Liquid may accumulate in the closure cap. To avoid splashes dispense slowly. Follow all safety instructions and observe limitations of use and operating limitations (page 4-6).

1. Remove closure cap and open discharge tube (Fig. 1).

Note:

Before using the instrument for the first time, ensure it is rinsed carefully and discard the first few samples dispensed. Avoid splashes.

2. Set valve to 'Recirculate' (Fig. 2).
3. For priming gently pull up the piston approx. 30 mm and push it down rapidly until the lower stop. Repeat this work step until there are no more air bubbles in the cylinder (Fig. 3).
4. Turn valve to 'Dispense' (Fig. 4).
5. To avoid splashes when priming hold the discharge tube on the inner wall of a suitable receiving vessel and dispense liquid to prime the discharge tube until it is bubble-free. Wipe away any remaining drops from the discharge tube (Fig. 5).

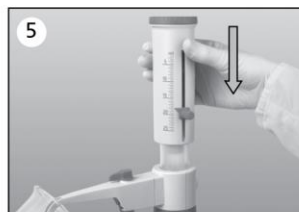
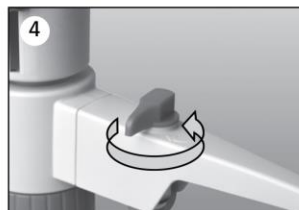
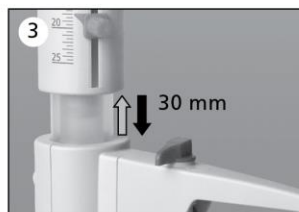
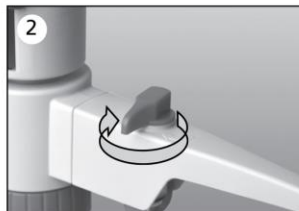

7. Dispensing

7.1. Setting the volume

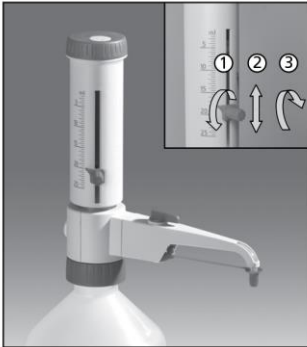

Variable: Loosen the volume selector thumb screw $\frac{3}{4}$ turn (1), set the pointer to the desired volume (2) and then retighten the volume thumb screw (3).

7.2. Dispensing

Warning!

Wear protective clothing, eye protection and gloves! Never press down the piston when the closure cap is put on! Avoid splashing the reagent! Liquid may accumulate in the closure cap. To avoid! splashes dispense slowly. Follow all safety instructions and observe limitations of use and operating limitations (page 4-6).

1. Remove closure cap of the discharge tube (Fig. 1).
2. Turn the recirculation valve to 'Dispensing'.
3. Hold the discharge tube orifice on the inner wall of a suitable receiving vessel.
4. Gently lift the piston until the upper stop and then depress piston slowly and steadily with minimal force until the lower stop (Fig. 2).
5. Wipe off the discharge tube against the inner wall of the receiving vessel.
6. Close discharge tube with the closure cap (Fig. 3).

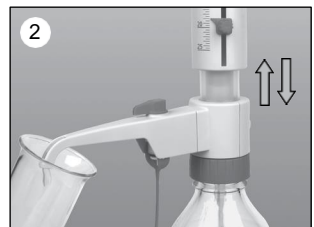

Caution!

After using the piston, always press it down to the lower stop.

8. Accessories

For dispenser the following optional accessories are available:

8.1 Flexible discharge tube with recirculation valve

For serial dispensing the flexible discharge tube can be used for the bottle-top dispenser („Accessories“, page 23). The specified accuracy and coefficient of variation of the instrument are only obtained for volumes > 2 ml and by gently approaching the upper and lower stops.

The coil of the tubing can be stretched to a length of the 800 mm max. The entire coil must lie in regular loops and must not be twisted.

The applicable operating exclusions are those for the corresponding instrument used (page 4-6).

1. Remove installed discharge tube.
2. The applicable operating exclusions are those for the corresponding instrument used.
3. Slide the discharge tube housing all the way up, then pull it forward with gentle up and down motions (Fig. 1).
4. Push the flexible discharge tube holder from the bottom of the valve block (Fig. 2) and tighten it. For this, the instrument must not be mounted on the bottle. Install the receiver tube.
5. Slide the flexible discharge tube housing into the valve block up to the stop (Fig. 3).
6. Slide the discharge tube housing all the way down (Fig. 4).
7. Place valve lever in position “Recirculate” and press in firmly.

Note:

Use a bottle stand („Accessories“, page 25).

Warning!

There should be no visible damage to the discharge tube (e.g. kinks or the like). Each time you are going to use the tubing, examine it carefully! To dispense aggressive liquids, you should take safety measures in addition to the normal precautions. We recommend use of a protective shield. The bottle must be supported using a bottle stand. To help avoid reagent splashing from the tube, always grip the tube firmly by the handle and replace into the holder after use. For cleaning rinse the tube carefully. Do not dismantle!

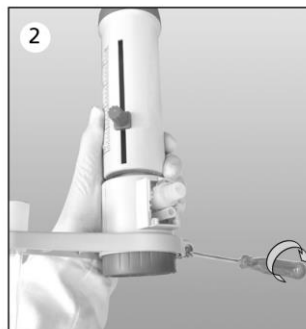
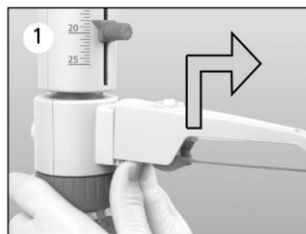

8.2 Drying tube

Use of a drying tube, filled with a suitable absorbent (purchased separately), might be necessary for moisture- and CO₂-sensitive media (‘Accessories’, page 25).

Assembly

1. Use a coin to unscrew the air vent cap (Fig. 1).
2. Screw the filled drying tube in (Fig. 2).
3. Place the PTFE sealing ring on the bottle thread (Fig. 3) and screw the instrument onto the bottle.

Note:

If necessary, seal the threads of the drying tube, the bottle and/or the bottle adapter with PTFE tape.

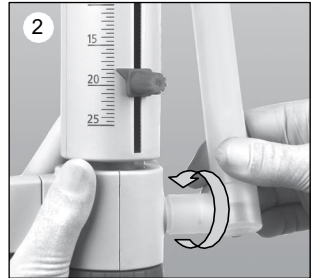
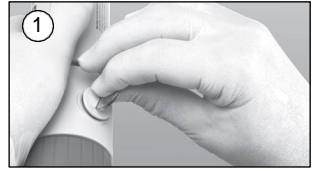

8.3 Sealing ring for valve block

For highly volatile media we recommend to seal the connection from valve block to bottle with the PTFE sealing ring and PTFE tape (see ‘Accessories’, page 25).

Assembly

Place the PTFE sealing ring on the bottle thread or the screwed-on adapter (Fig. 3) and screw the instrument onto the bottle.



8.4 Air vent cap for micro filter with Luer-cone

For sterile media we recommend the air vent cap with Luer-cone to attach a micro filter. This provides increased protection against contamination by displacement air (see ‘Accessories’, page 25).

Assembly

1. Unscrew the air vent cap (see ‘Assembly Drying tube’, Fig. 1).
2. Screw in the air vent cap with a Luer cone (Fig. 1).
3. Place the PTFE sealing ring on the bottle thread and screw the instrument onto the bottle.
4. Insert a commercially available sterile filter into the Luer cone (Fig. 2).



9. Error Limits

Error limits related to the nominal capacity (= maximum volume) indicated on the instrument, obtained when instrument and distilled water are equilibrated at ambient temperature (20 °C/68 °F). Testing takes place according DIN EN ISO 8655-6 with a completely filled instrument and with uniform and smooth dispensing.

DE-M



20 °C
Ex

Error limits

| Nominal volume ml | A* ≤ ± % | μl | CV* ≤ % | μl |
|----------------------|-------------|-----|------------|-----|
| 2 | 0.5 | 10 | 0.1 | 2 |
| 5 | 0.5 | 25 | 0.1 | 5 |
| 10 | 0.5 | 50 | 0.1 | 10 |
| 25 | 0.5 | 125 | 0.1 | 25 |
| 50 | 0.5 | 250 | 0.1 | 50 |
| 100 | 0.5 | 500 | 0.1 | 100 |

Partial volume

The percentage values for A and CV are relative to the nominal volume (V_N) and must be converted for partial volumes (V_p).

$$A_T = \frac{V_N}{V_p} \cdot A_N$$

| e.g. | Volume | A* ≤ ± % | μl | CV* ≤ % | μl |
|-------------------|--------|-------------|-----|------------|----|
| $\frac{V_N}{V_T}$ | 25.0 | 0.5 | 125 | 0.1 | 25 |
| $V_T = 50\% N$ | 12.5 | 1.0 | 125 | 0.2 | 25 |
| $V_T = 10\% N$ | 2.5 | 5.0 | 125 | 1.0 | 25 |

*A = Accuracy, CV = Coefficient of Variation

Note:

The error limits in DIN EN ISO 8655-5 are satisfied with a significant margin. The maximum error for a single measurement is calculated from the sum of error limits $EL = A + 2 \times CV$ (e.g., for the 25 ml size: $125 \mu\text{l} + 2 \times 25 \mu\text{l} = 175 \mu\text{l}$).

10. Checking the Volume (Calibration)

Depending on use, we recommend that gravimetric testing of the instrument be carried out every 3-12 months. This time frame should be adjusted to correspond with individual requirements. In addition, you can also perform a function test at shorter intervals, e.g. dispensing the nominal volume into a volumetric test flask.

Gravimetric volume testing according to DIN EN ISO 8655-6 (for measurement conditions, see 'Error Limits', page 14) is performed as follows:

1. Preparation of the instrument

Clean the instrument ('Cleaning', page 17-18), fill it with distilled H₂O and then prime it carefully.

2. Check the volume

- a) 10 dispensing operations with distilled H₂O in 3 Volume ranges (100 %, 50 %, 10 %) are recommended.
- b) For filling pull up the piston gently until the upper stop of the volume set.

- c) For discharge depress piston slowly and steadily without force until the lower stop.
- d) Wipe off the tip of discharge tube.
- e) Weigh the dispensed quantity on an analytical balance. (Please follow the operating manual of the balance manufacturer.)
- f) Calculate the dispensed volume. The Z factor takes account of the temperature and air buoyancy.

Calculations for nominal volume V_N

x_i = results of weighings

n = number of weighings

Z = correction factor

(e. g., 1.0029 µl/mg at 20 °C, 1013 hPa)

Mean value

$$\bar{x} = \frac{\sum x_i}{n}$$

Accuracy

$$A\% = \frac{V - V_N}{V_N} \cdot 100$$

Mean volume

$$\bar{V} = \bar{x} \cdot Z$$

Coefficient of variation

$$CV\% = \frac{100 s}{V}$$

Standard deviation

$$s = Z \cdot \sqrt{\frac{\sum (x_i - \bar{x})^2}{n - 1}}$$

11. Adjustment

After a long period of usage an adjustment of the instrument might be necessary.

- Calibrate for example at nominal volume (see page 15).
- Calculate mean volume (result of weighing) (see page 15).
- Adjust the instrument (to the calculated mean volume).
- After the adjustment, further calibration is necessary to confirm appropriate adjustment.

Example:

The gravimetric check gives an actual value of 9.90 ml for a 10 ml instrument set for a nominal volume of 10.00 ml.

1. Insert the pin of the mounting tool into the cover plate, and break it off with a rotating motion (Fig. 2). Discard the adjustment cover.
2. Insert the pin of the mounting tool into the adjustment screw (Fig. 3) and rotate to the left in order to increase the dispensing volume, or rotate to the right to decrease the dispensing volume (e.g. for an actual value of 9.97 ml, rotate approx. 1/2 turn to the left).
3. The change in the adjustment is indicated by a red disk (Fig. 4).

Adjustment range

| Nominal volume | Variable/Fix max. +/- | One rotation corresponds to |
|----------------|--------------------------|--------------------------------|
| 2 ml | 12 μ l | ~ 16 μ l |
| 5 ml | 30 μ l | ~ 40 μ l |
| 10 ml | 60 μ l | ~ 80 μ l |
| 25 ml | 150 μ l | ~ 130 μ l |
| 50 ml | 300 μ l | ~ 265 μ l |
| 100 ml | 600 μ l | ~ 400 μ l |

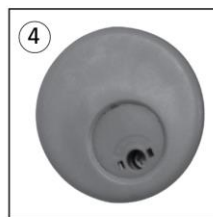
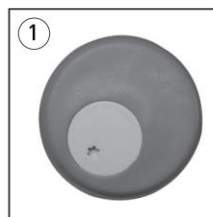

12. Cleaning

The instrument must be cleaned in the following situations to assure correct operation:

- immediately when the piston is difficult to move
- before changing the reagent
- prior to long term storage
- prior to dismantling the instrument
- prior to autoclaving
- prior to changing the valve
- regularly when using liquids which form deposits (e.g., crystallizing liquids)
- regularly when liquids accumulate in the closure cap

Warning!

The cylinder, valves, telescoping filling tube and discharge tube contain reagent! Never remove the discharge tube while the dispensing cylinder is filled. Point the valves and tube openings away from your body. Wear protective clothing, eye protection and appropriate hand protection.

For proper cleaning and removal of any deposits in the parts through which liquids pass, also always completely withdraw the piston from the cylinder after rinsing with a suitable cleaning solution. If necessary, the parts can also be cleaned in an ultrasonic bath.

1. Screw the instrument onto an empty bottle and empty it completely by dispensing. The instrument has to be emptied in both the 'dispense' (Fig. 1) and 'recirculate' settings (Fig. 2).
2. Screw the instrument onto a bottle filled with a suitable cleaning agent (e.g. deionized water) and rinse the instrument several times by completely filling and emptying it.

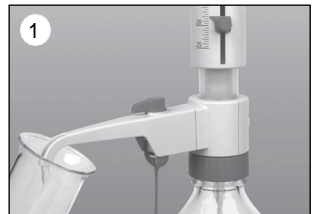

3. Disassembly of the piston.

Note:

The pistons and cylinders are individually matched, and should not be interchanged with piston from other instruments!

Hold the housing securely and unscrew the piston seat completely by turning it to the left (Fig. 1). Carefully pull out the piston (Fig. 2). Remove the housing.

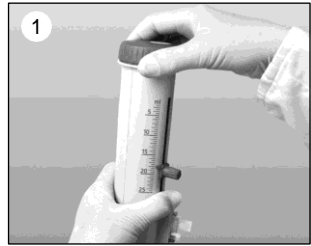

4. Clean piston and cylinder (Fig. 3).

If necessary carefully remove deposits at the edge of the glass cylinder.

5. Rinse the piston and cylinder with deionized water, and dry them carefully.

6. Reassemble the housing and then insert the piston completely into the cylinder and then reassemble the instrument.

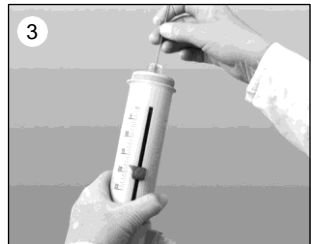
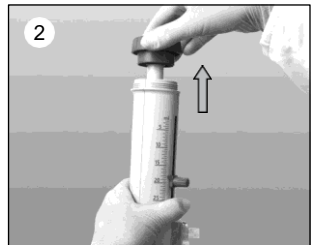

13. Replacement

13.1 Replacing the discharge tube

1. Set the recirculation valve to 'Recirculate', and the valve lever pulled upwards to remove (Fig. 1).
2. Slide the discharge tube housing all the way up, then pull it forward with gentle up and down motions (Fig. 2).
3. Hold coupling piece of the new discharge tube and pull housing up. Push housing into the valve block until it meets the stop.
4. Slide the discharge tube housing all the way down.
5. Pull up the valve lever to the 'Recirculate' position, and press it in tightly (Fig.3).

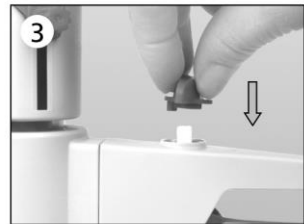
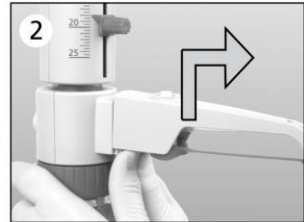
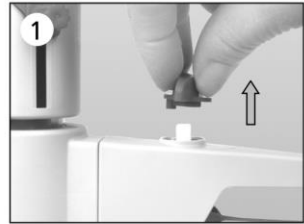

13.2 Replacing valves

13.2.1 Discharge valve

1. After disassembling the discharge tube (see 'Replacing the discharge tube' above), use the mounting tool to unscrew the discharge valve (Fig. 1).
2. Screw in the new discharge valve first by hand, then tighten it securely with the mounting tool (the threads should no longer be visible) (Fig.5).

Caution!

Always install the valve intended for the particular type and size of instrument! (see page 24 for 'ordering information').

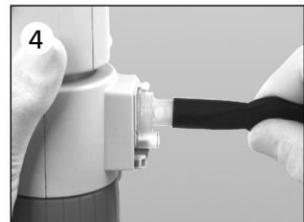

13.2 Replacing the discharge tube

13.2.2 Filling valve

1. Pull out the recirculation tube and the telescoping filling tube (Fig. 1).
2. Use the mounting tool to unscrew the filling valve (Fig. 2).
3. Screw in the new filling valve first by hand and then tighten it with the mounting tool.

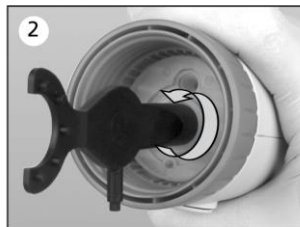

Note:

If the instrument does not fill up, and if some elastic resistance is evident when the piston is pulled upward, then it is possible that the ball valve is stuck.

In this case, loosen the ball valve using light pressure, for example, with a 200 µl plastic pipette tip (see the figure at the side).

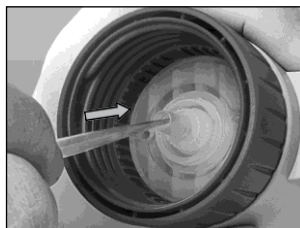

14. Autoclaving

The instrument can be autoclaved at 121 °C (250 °F), 2 bar with a hold time of at least 15 minutes according to DIN EN 285.

Preparation for autoclaving

1. The instrument must be carefully cleaned prior to autoclaving (see 'Cleaning', page 17-18).
2. Open the closure cap on the discharge tube, and set the recirculation valve to 'Dispense'.
3. Check that the filling valve is securely seated (Fig. 2).
4. To ensure unhindered access for the steam and to prevent the ball valve in the filling valve from possibly becoming stuck, hold the instrument with the discharge piston pressed vertically downward, and gently tap against the casing with your hand (Fig. 3).

Then lay it horizontally in the autoclave. Be sure to avoid the instrument coming into contact with metal surfaces in the autoclave!

Note:

Do not reassemble the instrument until it has cooled down to room temperature (Cooling time approx. 2 hours).

After every autoclaving, inspect all parts for deformities or damage. If necessary, replace them.

It is the user's responsibility to ensure effective autoclaving.

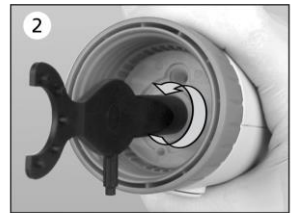
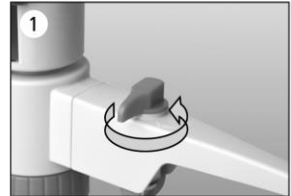

15. Ordering Information

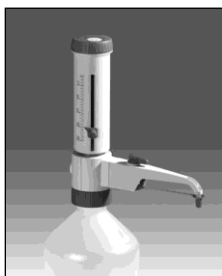

Dispenser variable

| Capacity ml | Subdivision ml | A* ± % | CV* ± % | Dispet EX II Cat. No. |
|----------------|-------------------|-----------|------------|--------------------------|
| 0.2 - 2.0 | 0.05 | 0.5 | 0.1 | 1625363 |
| 0.5 - 5.0 | 0.10 | 0.5 | 0.1 | 1625364 |
| 1.0 - 10.0 | 0.20 | 0.5 | 0.1 | 1625365 |
| 2.5 - 25.0 | 0.50 | 0.5 | 0.1 | 1623566 |
| 5.0 - 50.0 | 1.00 | 0.5 | 0.1 | 1625367 |
| 10.0 - 100.0 | 2.00 | 0.5 | 0.1 | 1625368 |

Note:

Items supplied see page 8.

16. Accessories and Spare Parts

The packaging unit is always 1 unless otherwise indicated!

Bottle adapters

PP or ETFE/PTFE. Adapters of ETFE/PTFE offer higher chemical resistance.

| Outer thread | for bottle thread/ ground joint | Material |
|--------------|------------------------------------|----------|
| GL 32 | GL 25 | PP |
| GL 32 | GL 28/S 28 | PP |
| GL 32 | GL 38 | PP |
| GL 32 | GL 45 | PP |
| GL 45 | GL 32 | PP |
| GL 38 | GL 32 | PP |
| GL 45 | GL 32 | PP |
| GL 45 | GL 38 | PP |
| GL 45 | S* 40 | PP |
| <hr/> | | |
| GL 32 | GL 25 | ETFE |
| GL 32 | GL 28/S 28 | ETFE |
| GL 32 | GL 38 | ETFE |
| GL 32 | S 40 | ETFE |
| GL 32 | GL 45 | ETFE |
| GL 38 | GL 32 | ETFE |
| GL 45 | GL 32 | ETFE |
| GL 45 | GL 38 | ETFE |
| GL 45 | S* 40 | PTFE |

* buttress thread



Discharge tube with recirculation valve

| Nominal volume ml | Length |
|----------------------|--------|
| 2/5/10 | 105 |
| 25/50/100 | 135 |



Filling valve
Valve: PFA/Boro 3.3/
ceramic.



Volume

2/5/10 ml
25/50/100 ml

Discharge valve
PFA/Boro 3.3/ceramic/
platinum-iridium.



Volume

2 ml
5/10 ml
25/50/100 ml

Telescoping filling
tubes
FEP. Adjusts to various
bottle heights.

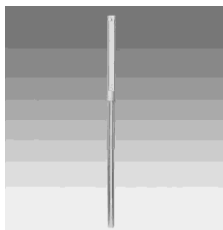

Recirculation tube
FEP.

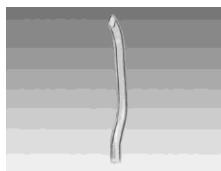

| Nominal volume ml | Outer-Ø mm | Length |
|-------------------|------------|---------|
| 2/5/10/ 25/50 | 6 | 70-140 |
| | | 125-240 |
| | | 195-350 |
| 100 | 7,6 | 250-480 |
| | | 170-330 |
| | | 250-480 |

Sealing ring for the
valve block
PTFE, for highly volatile
media.



Closure cap
with fastener, PP, red.



Volume

2/5/10 ml
25/50/100 ml

Calibrating-, mount-
ingtool



Flexible discharge tubing with recirculation valve, PTFE, coiled, length 800 mm, with safety handle.

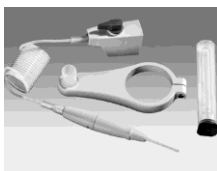

Drying tube (without drying agent) incl. PTFE-sealing ring (PTFE).

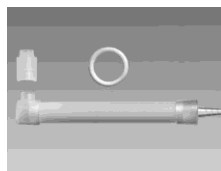

| Nominal volume ml | Discharge tube | |
|-------------------|----------------|------------|
| | Outer Ø mm | Inner Ø mm |
| 2/5/10 | 3 | 2 |
| 25/50/100 | 4.5 | 3 |

*not suitable for hydrofluoric acid

Bottle Stand PP, 325 mm, base plate 220 x 160 mm.

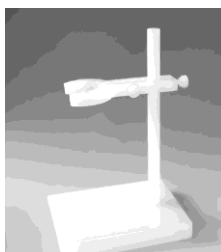

Air vent cap for micro filter with Luer-cone PP, air vent cap and PTFE-sealing ring.



17. Troubleshooting

| Problem | Possible cause | Corrective action |
|--|--|--|
| Piston moves with difficulty or is stuck | Formation of crystals, dirty | Stop dispensing immediately. Loosen piston with circular motion, but do not disassemble. Follow all cleaning instructions (page 17-18). |
| Filling not possible | Volume adjusted to minimum setting | Set to required volume (see page 11). |
| | Filling valve stuck | Unscrew the filling valve from the valve block, clean it, replace the filling valve if necessary. If the valve is stuck use a 200 µl pipette tip to loosen it (see page 20). If necessary replace the filling valve with sealing washer. |
| Dispensing not possible | Discharge valve stuck | Unscrew the discharge valve from the valve block, clean it, replace the discharge valve if necessary, use a 200 µl plastic tip to loosen any ball valve that is stuck. |
| Discharge tube or discharge tube with recirculation valve cannot be mounted sufficiently | Discharge valve is not screwed in deep enough | Tighten the discharge valve with the mounting tool until it meets the stop so that the threads are no longer visible. |
| Air bubbles in the instrument | Reagent with high vapor pressure has been drawn in too quickly | Slowly draw in reagent. |
| | Valve screw connections loose | Tighten the valves firmly with the mounting tool. |
| | The instrument has not been primed | Prime the instrument (see page 10). |
| | Filling tube is loose or damaged | Push the filling tube on firmly. If necessary cut off approx. 1 cm of tube at the upper end and re-connect it or replace filling tube. |
| | Valves not firmly connected or damaged | Cleaning procedure (see page 17-18). Tighten the valves using the mounting tool. |
| Dispensed volume is too low | Filling tube is loose or damaged | Cleaning procedure (see page 17-18). Push the filling tube on firmly. If necessary, cut off approx. 1 cm of the tube at the upper end and re-connect it or replace filling tube (see page 20). |
| | Filling valve is loose or damaged | Cleaning procedure (see page 17-18). Tighten the valves using the mounting tool. If necessary, replace filling valves. |
| Leaking liquid between instrument and bottle | Recirculation tube not connected | Connect recirculation tube (see page 8, Fig. 3). |
| | Volatile reagent dispensed without sealing ring | Mount sealing ring (see page 13). |
| | moisture-sensitive or CO ₂ sensitive media | Mount the seal ring for the valve block (see page 13) and use a drying tube filled with suitable absorbent (see page 13). |

18. Repairs - Kalibrierservice

18.1. Return for repair

Caution!

Transporting of hazardous materials without a permit is a violation of federal law.

- Clean and decontaminate the instrument carefully.
- It is essential always to include an exact description of the type of malfunction and the media used. If information regarding media used is missing, the instrument cannot be repaired.
- Shipment is at the risk and the cost of the sender.
- Complete the "Declaration on Absence of Health Hazards" and send the instrument to the manufacturer or supplier. Ask your supplier or manufacturer for the form.

18.2. Calibration Service

ISO 9001 and GLP-guidelines require regular examinations of your volumetric instruments. We recommend checking the volume every 3-12 months. The interval depends on the specific requirements on the instrument. For instruments frequently used or in use with aggressive media, the interval should be shorter. The detailed testing instruction can be requested from the manufacturer. Also there is the possibility to have your instruments calibrated by an Calibration Service.

19. Warranty

We shall not be liable for the consequences of improper handling, use, servicing, operation or unauthorized repairs of the instrument or the consequences of normal wear and tear especially of wearing parts such as pistons, seals, valves and the breakage of glass as well as the failure to follow the instructions of the operating manual. We are not liable for damage resulting from any actions not described in the operating manual or if non-original spare parts or components have been used.

20. Disposal



For the disposal of instruments, please observe the relevant national disposal regulations.

Subject to technical modification without notice. Errors excepted.

Vender

NICHIRYO CO.,LTD.

Website

<https://www.nichiryo.co.jp/en/>

Email

info@nichiryo.co.jp

●For inquiries, please use the contact form on our website or send us an email.

SB-DPXII001EN
